

BRASS TORCH KIT

⚠ IMPORTANT SAFETY INFORMATION

THIS PRODUCT USES EXTREMELY FLAMMABLE GAS AND IS VERY DANGEROUS IF NOT USED CORRECTLY. PLEASE READ THESE INSTRUCTIONS CAREFULLY AND KEEP THEM FOR FUTURE REFERENCE.

CHILDREN

- Children are precious. Do not let them near this gas torch, EVER!

PERSONAL PROTECTION

- Always wear protective gloves.
- Avoid contact with eyes or skin. In case of contact with eyes, rinse immediately with plenty of water and seek medical advice. For skin contact, flush with large amounts of water.
- Do not breathe the gas, fumes, vapor or spray. If inhaled, move to where there is fresh air.
- Radiant energy can harm your eyes. Wear glasses or goggles having appropriate UV protection.

VENTILATION

- Work only in well-ventilated areas. The fumes from fluxes, cadmium plating, brass, zinc and galvanized metal are toxic.
- Do not use in a confined work area or enclosed space.

CYLINDERS

- Keep cylinders away from heat or flame.
- Keep cylinders out of reach of children.
- Avoid prolonged exposure to sunlight.
- Do not store in temperatures above 50°C.
- Do not use if the cylinder is leaking, or the torch is damaged or malfunctioning in any way.

USING THE TORCH OUTDOORS

- Be cautious when using the torch outdoors on sunny or windy days.
- Bright sun makes it difficult to observe the flame.
- Wind may misdirect the flame towards you or other unintended areas or objects.
- Wind may further cause sparks to come in contact with unintended combustible materials.

GENERAL USE

- Never use torch as a cigarette lighter.
- Never use the torch to strip lead paint.
- Never use the torch on or near an aerosol can or any container that contains or has previously contained chemicals, or flammable materials, liquids or gases. Heating these is extremely dangerous, especially after they have been emptied.
- Be careful around motor vehicles or any gasoline-fired products and beware of any hidden fuel lines and tanks.
- When thawing pipes, be careful not to overheat surrounding parts.
- Heating a surface may cause heat to be conducted to adjoining surfaces that may be combustible or become pressurised when heated. Always check to make sure no unintended parts or materials are being heated.

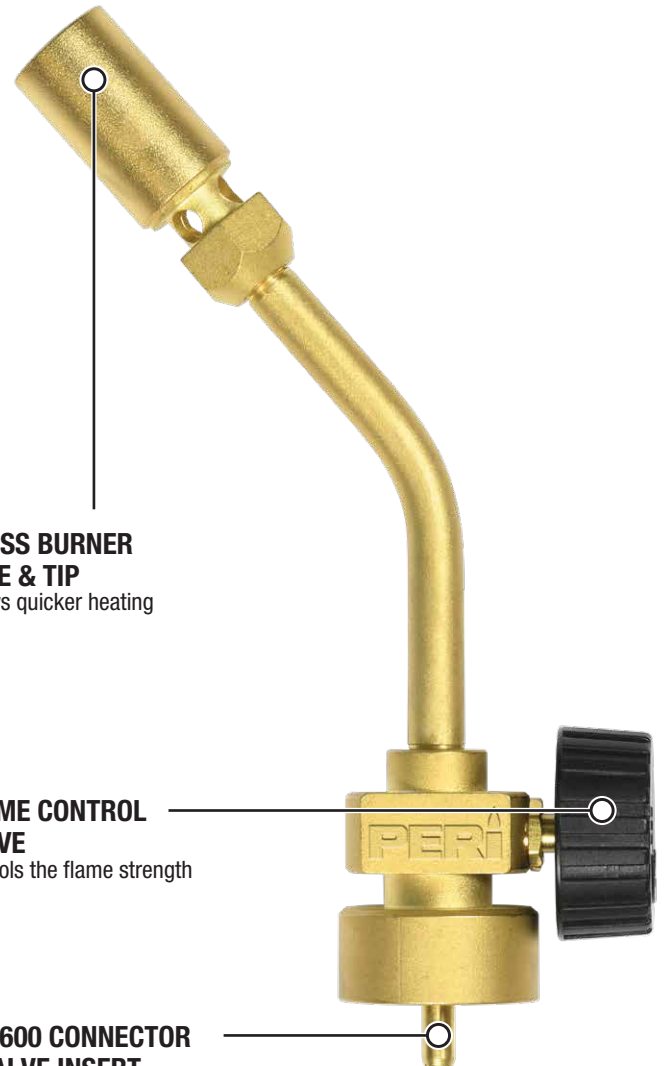

BRASS BURNER TUBE & TIP
Allows quicker heating

FLAME CONTROL VALVE
Controls the flame strength

CGA600 CONNECTOR & VALVE INSERT
Connects to all common brands

KEEP THESE INSTRUCTIONS

ASSEMBLY

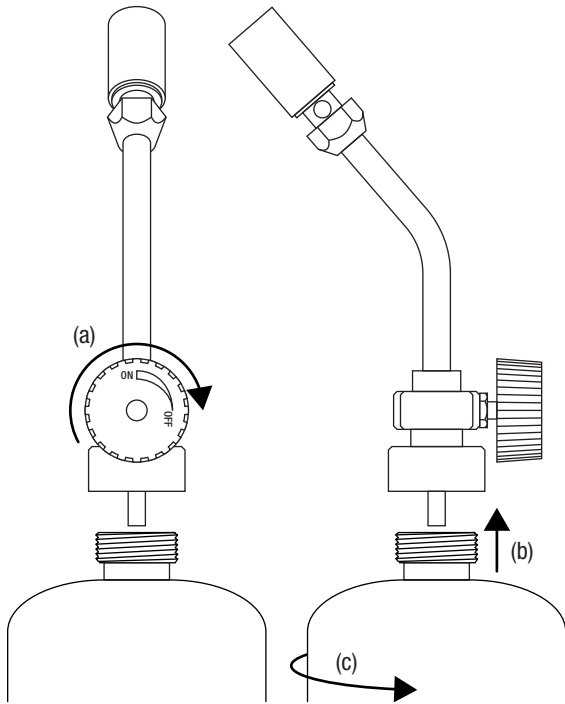

- Before assembly, check all parts function correctly and are not damaged.
- Make sure valve is OFF by turning knob in direction of arrow until hand tight only (a). DO NOT FORCE.
- Push the fuel cylinder firmly into the valve body (b) and turn clockwise until hand tight (c). DO NOT FORCE.

LIGHTING

THE TORCH CAN BE LIT WITH EITHER A MATCH OR A SPARK LIGHTER

- To light with a match or naked flame, hold as shown and open the valve (a) slowly.
- To light with spark lighter, open the valve (a) slowly before sparking. Hold spark lighter at a 45° angle to the torch opening. NOTE: It is very difficult to light with the valve fully open.
- Do not open the valve and allow gas to flow through the torch without attempting to ignite the torch.
- If ignition does not occur after approximately 20 seconds, close the valve and wait a few minutes before attempting to ignite again. This will prevent a build up of flammable gas in the air which could easily ignite into a dangerous fireball.
- In cold weather the torch will be harder to light and the size of the flame will be smaller. Pre-warming the cylinder to room temperature will make the torch easier to light and produce a larger flame.
- For the hottest, most efficient flame, adjust inner blue flame to 40-50mm length.

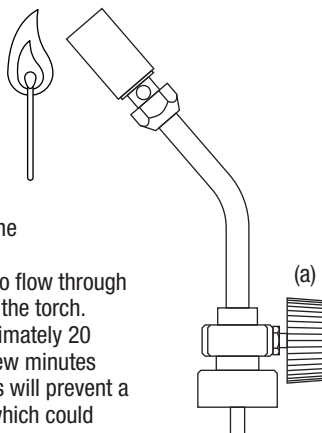

USING

KEEP A FIRE EXTINGUISHER NEAR WHERE YOU ARE USING THE TORCH AND WHERE YOU STORE THE TORCH

- Always use the torch in mainly an upright position. Tipping the gas cylinder more than 60° from its upright position may cause the torch to flare. Never use upside down. If the torch is moved rapidly, tilted too far to the side or upside down, propane liquid can enter the valve and cause the flame to flare or extinguish.
- Always point the torch flame away from your body, and never towards other persons or any object that is flammable.
- Be aware that the tip of the torch can get extremely hot during use.
- Always make certain the torch is placed on a level surface when connected to a gas cylinder to reduce the risk of accidental tip over.
- Never leave the torch unattended when lit.
- Disconnect the torch from the cylinder when not in use.

MAINTENANCE

WE RECOMMEND PERIODIC MAINTENANCE WHEN THE TORCH IS USED REGULARLY

- Make sure the torch is cool before tightening or removing the burner head, or before installing or removing accessories.
- Check all joints and couplings periodically to ensure there are no loose connections. With valve open, without lighting, test all connections with soapy water. If bubbles appear, gas is leaking and the torch must be repaired. NEVER USE A FLAME TO CHECK FOR LEAKS. Make this test in a well-ventilated and spark-free area, and where there are no open flames.

STORAGE

REMOVE CYLINDER FROM TORCH WHEN NOT IN USE

- Turn the valve off.
- When the torch is cool, disconnect the cylinder and store the torch and cylinder separately and out of reach of children. Observe cautions on cylinder label.
- Do not store near any heat source or in a room used for habitation.

DISPOSAL OF CYLINDER

WHEN THE CYLINDER IS EMPTY

- Do not refill (it is illegal and unsafe). You will need to purchase a new one.
- Do not puncture or incinerate.
- Do not throw into a fire.
- Dispose of in a safe place where children can't find it.

TROUBLESHOOTING

MY GAS TORCH DOESN'T BURN HOT ENOUGH

- Check that the gas bottle is not getting low.
- Adjust inner blue flame to 40-50mm length using the Flame Control Valve.

MY GAS TORCH WON'T IGNITE

- Check that the gas bottle is not empty.
- Ensure the Flame Control Valve is turned on full to allow maximum gas before igniting.

KEEP THESE INSTRUCTIONS